



LAYOUT DIAGRAM 原理图: (FIG-1)

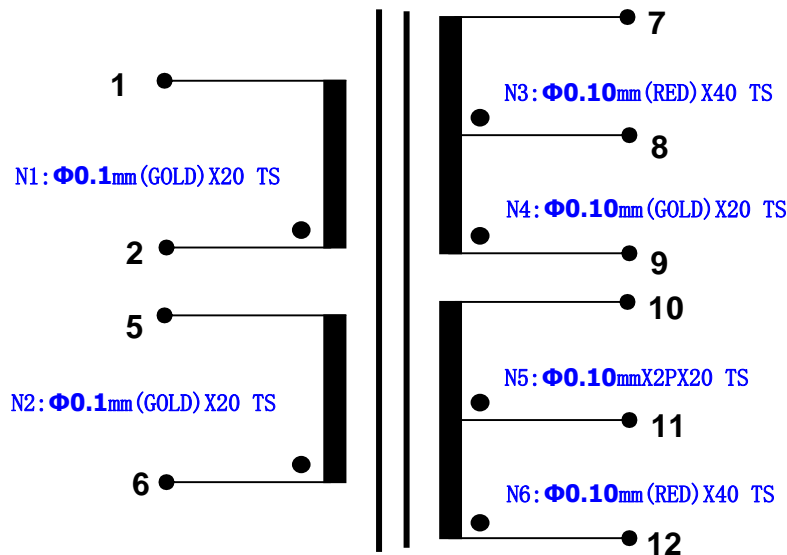

FIG-1

DATA SPECIFICATION (特性要求): (TABLE-1)

ITEM 项目	MEASUREMENTS 测试脚位	CHARACTERISTICS 测试范围	MEASURING CONDITIONS 测试条件 T=25°C ± 3; HR (%) = 45 ± 15	REMARK 备注
LS 电感	PIN(2-1)	20.8uH ± 12%	F (kHz) = 10 Ug (V) = 0.1	SERIAL MODE 串联模式
	PIN(6-5)	20.8uH ± 12%	F (kHz) = 10 Ug (V) = 0.1	SERIAL MODE 串联模式
	PIN(8-7)	83.2uH ± 12%	F (kHz) = 10 Ug (V) = 0.1	SERIAL MODE 串联模式
	PIN(9-8)	20.8uH ± 12%	F (kHz) = 10 Ug (V) = 0.1	SERIAL MODE 串联模式
	PIN(11-10)	20.8uH ± 12%	F (kHz) = 10 Ug (V) = 0.1	SERIAL MODE 串联模式
	PIN(12-11)	83.2uH ± 12%	F (kHz) = 10 Ug (V) = 0.1	SERIAL MODE 串联模式
COPLANARITY 共平面度	ALL PINS	0.25mm MAX.		
PH 相位	REFER TO LAYOUT DIAGRAM (FIG-1) 参考原理图 (FIG-1)			

Prepared By ENG:	Date:	TITLE: SMD POWER INDUCTOR	CUSTOMER	MODEL NO. : TBP12XXX-00	
Checked By QA:	Date:		Approved:	REV.	00
Approved By ENG:	Date:		Date:	PAGE	1 OF 2



OUTLINE DIAGRAM (外观图) :

UNIT: mm

Tolerance unless otherwise specified: ±0.3

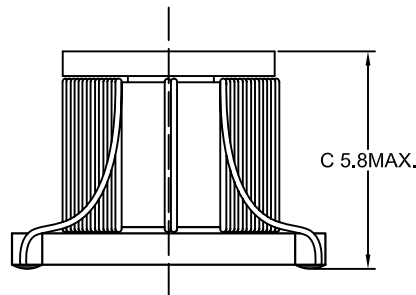
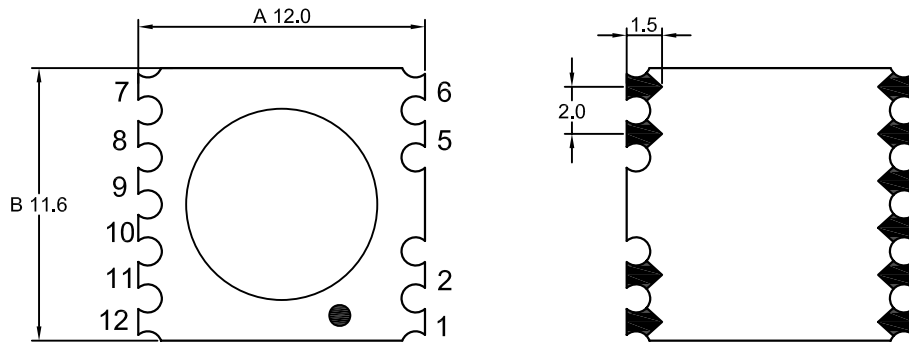

NOTE:

1. Fix the coil and base with EPOXY.
用胶将coil 和base固定在一起.
2. The parts should be complied ROHS requirement.
产品需满足ROHS需要.
3. All windings evenly distributed around the core.
所有绕组360° C平铺于CORE.

Prepared By ENG:	Date :	TITLE : SMD POWER INDUCTOR	CUSTOMER Approved: Date:	MODEL NO. : TBPL2XXX-00	
Checked By QA:	Date :			REV. :	00
Approved By ENG:	Date :			PAGE 2 OF 2	

免责声明

Disclaimer

Specifications and appearances may change without notice. All statements, technical information and recommendations herein are based on tests that we believed to be reliable, but the accuracy and completeness are not guaranteed. Before using, user should determine the suitability of the product for its intended use, and the user assumes all risks and liabilities whatsoever in connection therewith. Neither the seller nor the manufacturer shall be liable for any loss or damage, direct, incidental or consequential, including loss of profits or revenues arising from the use or inability to use the product. Any statements or recommendations shall have no effect unless contained in an agreement signed by authorized personnel of the seller and manufacturer.

依美电感保留更改产品资料和外观的最终权利而无需事先通知。如有任何争议，依美电感保留最终决定权。此中文免责声明为英文版本译本，如中、英文两个版本有任何抵触或不相符之处，应以英文版本为准。