

SMD Current Sensors

- SCT 6 Amp Series

DOT BY PIN1

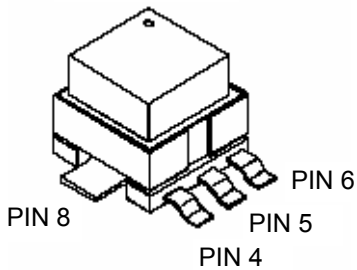

Description

- Low profile surface mount
- Designed for switch mode power supply application
- Compatible with surface mount process temperatures
- UL class H 180°C

Application

- Switching power supplies
- AC current detection
- Output supply for control circuitry
- Appliance, medical equipment, office equipment



Mechanical Drawing

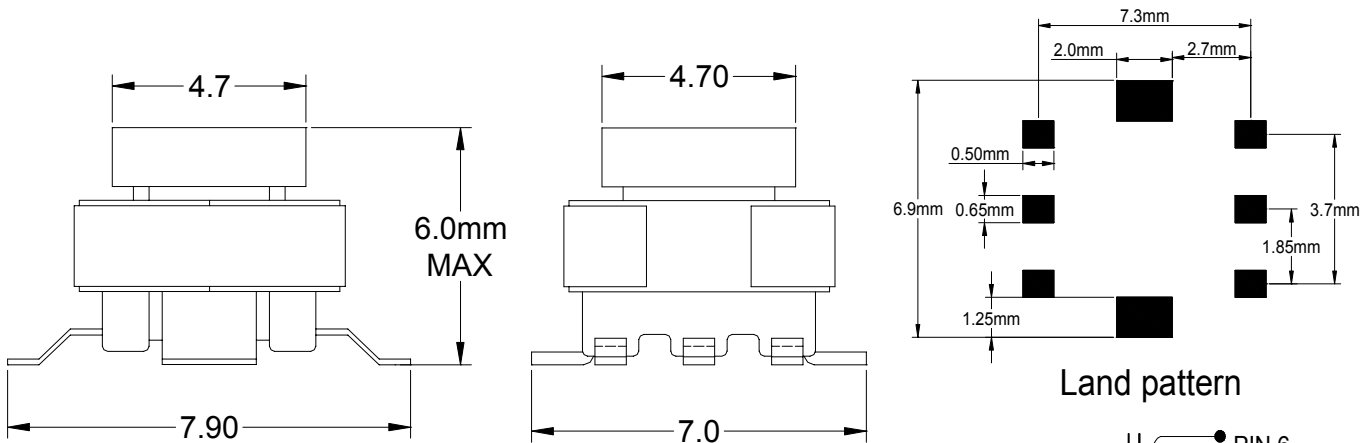

Land pattern

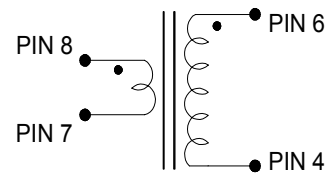

Schematic

Electrical Properties

Part Number	Secondary Inductance (mH)	Secondary D.C. Resistance ($\Omega \pm 15\%$)	Turn Ratio	Primary Current (A Max.)
SCT02-070	0.98	4.52	1 : 70	6
SCT04-200	8.00	14.00	1 : 200	6

Note:

- Inductance test at 10KHz, 1Vrms
- D.C. Resistance measured at 20°C
- Hipot 500 VDC

Packaging

- 1000 pcs per reel