



Data Specification (特性要求) : (Table-1)

ITEM 項目	MEASUREMENTS 测试腳位	CHARACTERISTICS 测试範圍	MEASURING CONDITIONS 测试條件 T(°C)=25±3;HR(%)=45±15	REMARK 備注
LS 電感	PIN(6-7)	25uH MIN.	F(kHz)=1 Ug(V)=0.1	SERIAL MODEL 串聯模式
DCR 電阻	PIN(6-7)	20mΩ MAX	/	4 WIRE MODEL 四线模式
	PIN(2-3)	220mΩ MAX	/	4 WIRE MODEL 四线模式
	PIN(4-5)	220mΩ MAX	/	4 WIRE MODEL 四线模式
HIPOT 耐壓	PRI./SEC.	NO Breakdown 漏電流≤5.0mA	VAC=710V/2SEC F(Hz)=50	/
	COIL/CORE	NO Breakdown 漏電流≤5.0mA	VAC=710V/2SEC F(Hz)=50	/
TR 圈比	(2-3)/(4-5)	12:12±0.5%	F(kHz)=10 Ug(V)=1	Apply Ug(2-3) 电压施加于(2-3)
	(2-3)/(6-7)	12:5±0.5%	F(kHz)=10 Ug(V)=1	Apply Ug(2-3) 电压施加于(2-3)
COPLANARITY 共平面度	ALL PINS	0.15mm MAX.	/	/
PH 相位	REFER TO LAYOUT DIAGRAM FIG-1 参考原理图 (FIG-1)			

Prepared By ENG:	Date:	TITLE: TRANSFORMER	CUSTOMER Approved: Date:	MODEL NO:EP13	
Checked By QA:	Date:			REV.	00
Approved By ENG:	Date:			PAGE	1 OF 3



OUTLINE DIAGRAM (外观图) :

UNIT : mm

Tolerance unless otherwise specified: .X ± 0.762 .XX ± 0.127

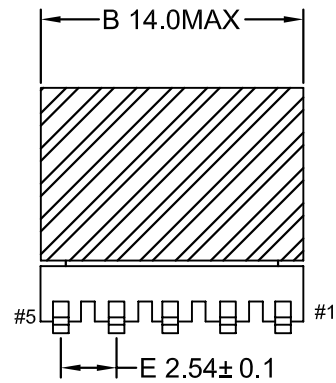
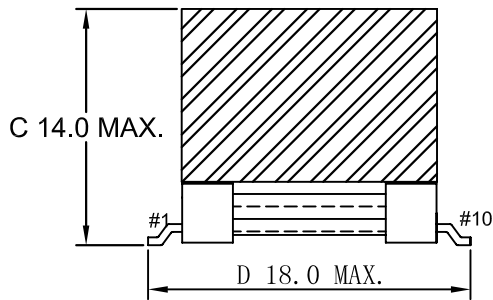
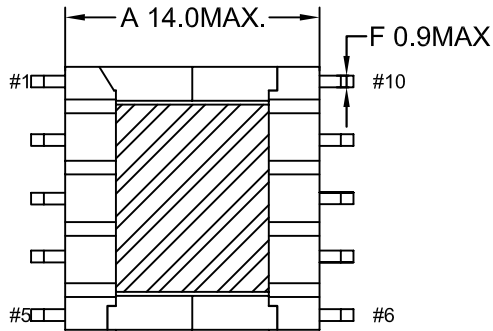

NOTES:

1. Assembly the 2 magnetic cores on the bobbin with 2 layers 7.5mm width tape .
用2层7.5mm宽的胶带将两铁芯组装在胶芯上.
2. The transformer must be in varnish .
产品需含浸凡立水.
3. The product should be according to RoHS
产品要符合RoHS
4. YYWW: year week code.
YYWW:周期年份代码.

Prepared By Eng:	Date :	TITLE : TRANSFORMER	CUSTOMER Approved: Date:	MODEL NO. :EP13	
Checked By Qa :	Date :			REV.	00
Approved By Eng:	Date :			PAGE 2 OF 3	



LAYOUT DIAGRAM (原理图): (FIG-1)

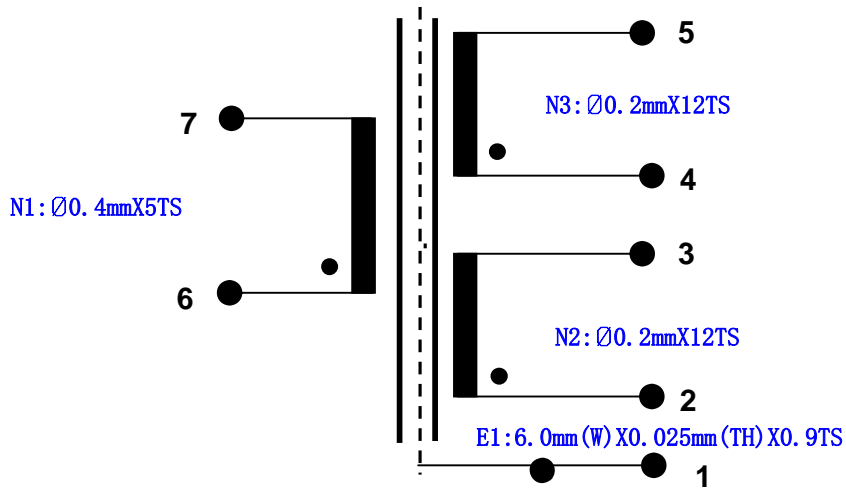

PRI.

FIG-1

SEC.

REMARK:

N2&N3 BIFILAR WINDING

CROSS SECTION DAGRAM剖视图: (FIG-2)

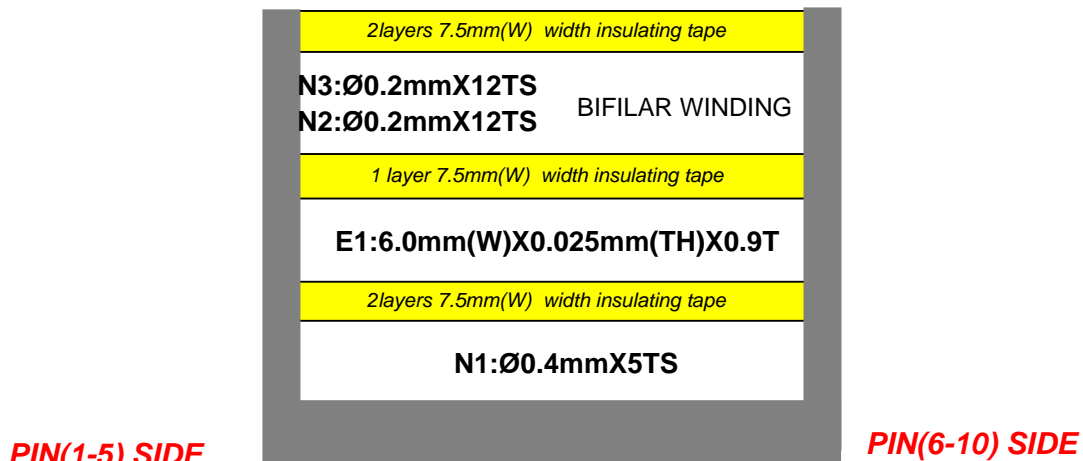

FIG-2

Prepared By ENG:	Date:	TITLE: TRANSFORMER	CUSTOMER Approved: Date:	MODEL NO:EP13		
Checked By QA:	Date:			REV.	00	
Approved By ENG:	Date:			PAGE	3	OF

免责声明
Disclaimer

Specifications and appearances may change without notice. All statements, technical information and recommendations herein are based on tests that we believed to be reliable, but the accuracy and completeness are not guaranteed. Before using, user should determine the suitability of the product for its intended use, and the user assumes all risks and liabilities whatsoever in connection therewith. Neither the seller nor the manufacturer shall be liable for any loss or damage, direct, incidental or consequential, including loss of profits or revenues arising from the use or inability to use the product. Any statements or recommendations shall have no effect unless contained in an agreement signed by authorized personnel of the seller and manufacturer.

依美电感保留更改产品资料和外观的最终权利而无需事先通知。如有任何争议，依美电感保留最终决定权。此中文免责声明为英文版本译本，如中、英文两个版本有任何抵触或不相符之处，应以英文版本为准。